



Instruction Manual for POC Bushings

1. Scope

This instruction contains general procedures to be followed during receiving, installation, storage and maintenance of all PCORE POC bushings. This instruction does not cover all contingencies that may arise during installation, operation, or maintenance of such equipment. If you require additional information regarding a particular installation and the operation or maintenance of your bushing, contact PCORE. PCORE does not assume any liability or responsibility for any damage or failure that would result from improper transportation, application, installation, storage, or maintenance.

2. Safety

These tasks may cause safety hazards if they are not performed properly. Those who are responsible for or involved in the installation, maintenance, storage and operation of the bushings must read this instruction and understand the details before they perform the tasks. Required procedures and instructions must be followed when installing bushings on apparatus or building (hereafter, any equipment or buildings on which bushings are to be installed will be called apparatus).

All applicable safety procedures such as OSHA requirements, regional and local safety requirements, safe working practices and good judgment must also be used by personnel when installing, operating and maintaining such equipment.

Some of the hazards associated with these tasks are:

Lethal electric shock

Fire or burning due to high current

Lifting hazards

Heavy equipment

High pressure

Hot oil

Hazards will be identified by the three following categories:

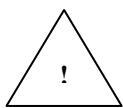

DANGER

*Immediate hazard, which **WILL** result in **SEVERE** personal injury, death, or property damage.*

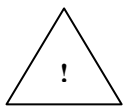

WARNING

*Hazard or unsafe practice, which **MAY** result in **SEVERE** personal injury, death, or property damage.*



CAUTION

*Hazard or unsafe practice, which **MAY** result in **MINOR** personal injury or property damage.*

3. Bushing Components

3.1 Housings

The top and bottom insulating housings are made of electrical grade porcelain. The porcelain is completely vitrified and is NOT POROUS. Chips or small broken petticoats WILL NOT affect performance. BROKEN PORCELAIN DOES NOT NEED TO BE SEALED FROM MOISTURE.



CAUTION

*Broken porcelain is **EXTREMELY** sharp. Gloves must be used when handling broken porcelain.*

3.2 Conductors

Lower current bushings have aluminum conductors and high current bushings have copper conductors.

3.3 Insulation Materials

Standard POC bushings use electrical grade Kraft paper. High temperature bushings use Nomex[®], high temperature gaskets and o-rings.

3.4 Oil Expansion Tanks

Three types of oil expansion tanks are used on PCORE POC bushings: cylindrical sight glass, metal tank with "eyeball" sight glass, metal tank with oil level gage.

3.5 Oil Level Indicators

The following are the recommended oil levels at 25°C with the bushing in a vertical position. A bushing with either sight glass should show half full. A magnetic oil level pointer should indicate 25°C.

Slight variation in levels due to ambient conditions can be expected and are not an indication of oil loss or over filling.

3.6 Flanges and Flange Adapter

Flanges and flange adapters are made of aluminum. For replacing older bushings or other manufacturers bushings, PCORE offers custom-made flange adapters.

3.7 Terminals

Terminals are copper or brass. Some are silver or tin plated.

4. Types of Apparatus Cable Connections

4.1 Bottom Connections

PCORE POC bushings have one of the following bottom terminals: Flat spade or threaded stud. The bushings with a flat spade can be directly connected to the apparatus. The bushings with a threaded stud MAY need adapters to connect to the apparatus.

4.2 Draw Lead Connections

Some bushings are designed with a hollow conductor through which a flexible cable or a rod can be pulled. The cable is a part of the apparatus on which the bushing is mounted and is not supplied with the bushing. Most draw-lead terminals have a flat spade for brazing, crimp type, or tubular brazing terminals are available.

4.3 Transformer and Oil Circuit Breaker Interchangeability

The 800 ampere draw-lead bushings in the 115 kV through 230 kV class can be bottom connected for 1200 ampere transformer rating and can also be 1600 ampere bottom connected for oil circuit breaker application.

PCORE POC bushings can provide maximum interchangeability between transformer and oil circuit breaker applications with the same basic bushing by just changing some hardware. The current rating for transformer application is based on the maximum oil temperature of 95° C while that for the oil circuit breaker application is on the maximum oil temperature of 80°C.

5. Crates

Three types of crates are used. Small bushings are shipped in wire-bound crates. Large bushings are shipped in crates with top covers held in place with reusable fasteners. The top covers of export bushings are nailed. POC bushings in the 15 kV through 69 kV class are shipped in the horizontal position in crates. The top end of bushings in the 115 kV through 230 kV class are shipped at a 5° to 7° angle to keep the paper insulation immersed totally in oil. EHV bushings (greater than 230 kV) are shipped in the horizontal position in crates because they are too large to keep on an angle.

6. Receiving and Incoming Inspections

You should perform a visual inspection on the crate and the bushing before unloading. When unloading crates, you must take extreme care not to damage the crates or the bushings. Do not drop the bushings. The bushings should be unpacked in a flat, dry area

To open the wire bound crate, the twisted wires should be straightened with pliers. The clips (on crates with reusable clips) can be removed using a claw hammer. Remove any nailed covers carefully to avoid damage.

Some crates contain separate boxes containing special terminal adapters, bottom shields, oil reservoir tanks for horizontally mounted bushings, draw-lead extensions or other special parts. These special parts should also be checked for damage from shipment.

Examine the porcelain for cracks or chips. Check all seals for oil leakage. Although surface oil is removed from the bushing after electrical testing, occasionally a gasket seal may weep an oil film when received. To check for gasket seal leakage, wipe the suspected joints clean and observe for a period of 48 hours. If oil leakage is detected, contact the factory at Le Roy. Any special parts should be checked for damage.

If shipping damage is evident, you must file a claim with the transportation carrier and notify PCORE of the claim immediately.

7. Storage

The preferred way of storing bushing is to keep them vertical in a proper stand, which cannot be tipped over. The preferred location is indoors, however bushings may be stored outdoors. The crates are not made for extended outdoor storage, inspect the crates periodically for weather damage. It is important that the paper core be completely submerged in oil.

Small bushings, shipped in wire-bound crates may be stored vertically in the crates, as long as they are kept indoors.

Bushings shipped in crates at an angle can be stored on a flat surface in the shipping crate.

The top end of larger bushings (greater than 230kV) and low-voltage, high current bushings (25 kV through 69 kV) should be raised about 7 degrees. The bottoms of crates for EHV bushings must be supported in several places to prevent crate damage.

For long term outside storage, moisture or water may gather inside the protective plastic bag that covers the upper and lower porcelain. Suitable protection, such as water-repellent grease should be provided for top and bottom terminals, and mounting hardware to protect the contact area from corrosion. Under these conditions, the voltage tap housing should be filled with clean, dry transformer oil. This will prevent condensation and corrosion of the threads.

8. Handling and Installation

8.1 Removing Bushings from Crates

8.1.1 88xxx Series 25 kV ~ 69 kV Bushings (Vertical or Horizontal Mounting)

PCORE POC bushings in the 25 kV through 69 kV class can be removed from the crate using a nylon choker around the upper porcelain. Position the bushing vertically, and check the oil level of the bushing before installation.

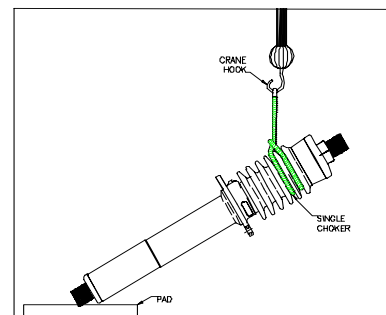

8.1.2 GSU Bushings

PCORE GSU bushings must be removed from the crate while in the horizontal position. The center of gravity is not at the flange so a double sling must be placed between the porcelain at the air end of the bushing and the porcelain on

the oil end of the bushing. Once the bushing is removed from the crate and placed horizontally on a pad, eyebolt may be attached to the top terminal to lift the bushing from horizontal to vertical and into the apparatus.

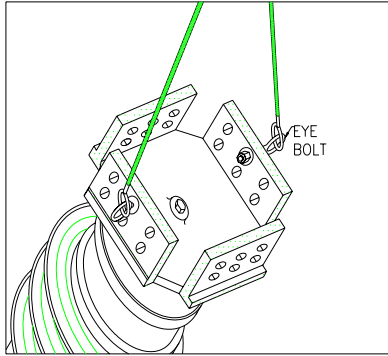

Eyebolts must be placed in the vertical terminals only, lifting from the horizontal terminal may cause damaged to the terminal alignment..



Do not attempt to lift bushing from the shipping crate by the top terminal alone. The angle of the flange in the shipping crate may cause binding and extreme cantilever loading on the terminal, which may cause damaged to the bushing.

Do not use a single sling around the top porcelain shed as a means of lifting. This unbalance may cause severe pressure against the porcelain shed.

8.1.3 115 kV ~ 800 kV Bushings

These PCORE POC bushings are provided with lifting eyes in the flange. Because of the size and weight of the bushings, they may require special handling. Before lifting a bushing, remove any mounting flange bolts holding the bushing in the crate and any other method of support which may be used to secure the bushing.

The main lifting tackle should always be attached to the flange lifting eyes. A second crane hook must be attached to a double sling with a choker rope tied around the bottom of the top porcelain.

For 115 kV through 230 kV class bushings:

Tie two choker ropes around the top porcelain under the top petticoat. Attach two slings to one crane hook. Pass the other end of the sling through the eyes of each choker rope. Attach a shackle to each of these ends. Connect the shackles to the lifting eyes of the mounting flange 180 degrees apart.

Pass a sling through eyes of mounting flange and attach both ends to the second crane hook. If it is not easy to pass the sling through the eyes of the flange, you may tie a choker

rope with a **sufficient strength** under a petticoat close to the bottom petticoat. Attach a sling to the second crane hook. Attach the end of choke rope to the hook.

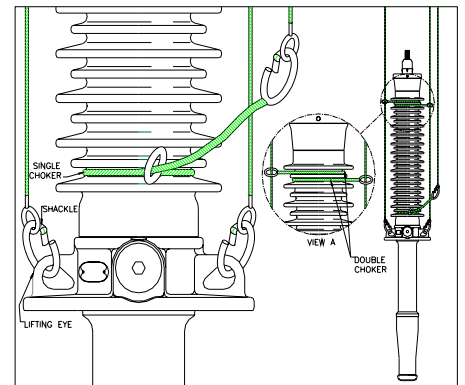
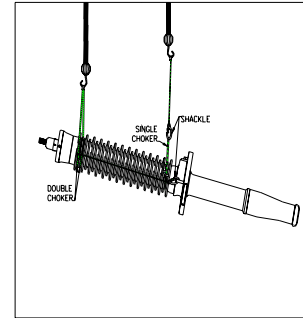

For the 345 kV through 765 kV class:

From one crane hook, use two slings or a double sling passed through a spreader bar and attach the lower end of the slings to the mounting flange lifting eyes. The spreader bar is not provided but such a bar must be used. The slings should be long enough so when the bushing is vertical the bushing will pass through and under the spreader bar.

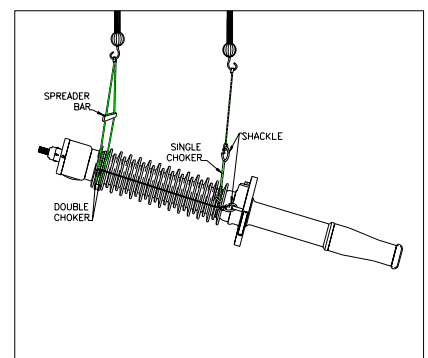

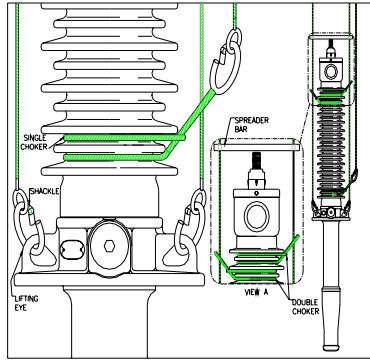

From the second crane hook attach a sling to the a choker around the bottom of the top porcelain 90 ° degrees from the flange lifting eyes. This crane will be used to pivot the bushing only while the flange crane by way of the spreader bar will support the main weight of the bushing.

Lift the bushing by raising both crane hooks simultaneously maintaining the air end of the bushing slightly above the oil end until ready to lower the oil end of the bushing.

Under certain conditions it may be advantageous to remove the bushing from the crate first to accommodate placement of the choker sling or placement of shackles on the flange. Under these conditions a sling or choker around the porcelain is acceptable and a sling through the flange lifting eyes would be adequate to raise the bushing and maintain a slight angle. The bushing can be removed and placed on adequate support, which will keep the air end raised while adjusting the slings and cables.

When ready to lift the bushing for mounting, raise both crane hooks simultaneously while maintaining the air end at a slightly higher angle by lowering the crane hook attached solely to the flange. The entire weight of the bushing will be held by the two slings through the choker and attached to the flange lifting eyes. The angle of orientation can be adjusted by the raising and lowing of each crane.



Do not place a choker sling or rope above the top shed between the porcelain and the metal cover. The metal dome on PCORE bushings consists of a spinning and may be damaged from sling pressure.



Do not attempt to lift the bushing by a sling on the porcelain alone.

After the bushing is upright, check to ensure the internal bushing oil is at the correct height in the sight glass or that the magnetic oil level indicator is showing the proper oil level.

8.2 Cleaning

Bushings should be kept vertically in a secure stand and you must remove all dust, grease, oil or particles of packaging from the bushing with clean dry cloth. Especially the lower

porcelain and flange should be wiped clean of dust or dirt to prevent contamination of transformer oil. Before mounting bushings to the apparatus cover, inspect and clean the mounting surfaces of both the bushing and apparatus.

Check the inside wall of draw-lead tube especially when the bushing has been stored outdoors a long time. If it is dirty, remove all the dirt, dust and other foreign materials from the wall.

8.3 Electrical Tests

PCORE recommends that power factor and capacitance measurements be performed on all bushings before installation. The measured values should be compared with those on the nameplate. The nameplate values are of special importance in asking PCORE questions about bushings. The bushing must be kept vertically in a secure stand for the electrical tests.

The methods of measuring power factor and capacitance are in the user manual of your power factor measuring device or consult IEEE Standard 62-1995 *IEEE Guide for Diagnostic Field Testing of Power Apparatus Insulation*. Only C₁ power factor and capacitance have meanings for the 25 kV through 69 kV class bushings. PCORE recommends against measuring C₂ power factor and capacitance of this voltage class bushings for any purpose.

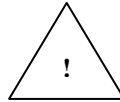

Do not operate the bushing without the test tap or voltage tap cover in place.

PCORE recommends measuring C₁ and C₂ power factors and capacitances of the bushings rated 92 kV and above prior to the installation. PCORE POC Bushings rated 92 kV and above use a voltage tap located just above the flange which is normally grounded in operation by means of a ground clip in the tap cover. Unless a potential device is used, this cover must always be installed during operation of the bushing.

These measurements should agree with the nameplate values within equipment tolerances and should be kept as reference readings. When power factor and capacitance readings are in disagreement with nameplate data beyond reasonable tolerances, you should contact the factory at Le Roy.

Never test the bushing while in the shipping crate.

When possible, place the bushing in a grounded test stand. It is important to isolate the flange from the grounded stand using a good insulating material. Wood can contain significant moisture and should never be used.



The readings may be taken with the bushing installed in the equipment provided the top terminal connections are not made or the terminal is isolated from the main bus via a PCORE-Doble Test terminal.

After the testing has been completed, reassemble the tap cover after coating the "O-ring" lightly with silicone grease and tighten the cap.

8.4 Mounting Bushings

If the bushings are stored horizontally, it is important to remove all entrapped air from the core. Place the bushing in the vertical position and shake the oil end to force any air bubbles out of the core area before installation. **Do not apply voltage for at least 24 hours after installation for the bushings rated below 230 kV and at least 48 hours for the bushings in the 230 kV class and above**

8.4.1 Mounting Angle

PCORE bushings with oil level sight glasses are designed for safe operation in vertical position or at angles up to 70 degrees from vertical. Bushings with metal domes using magnetic oil level gauges should not be used at angles exceeding 30 degrees from the vertical and should be mounted with the magnetic oil level gage facing downwards. PCORE bushings should not be mounted horizontally unless the bushing is furnished with a supplementary oil reservoir.

8.4.2 Vertical Mounting

Lift the bushings in the same way as removing bushings from the crates. If a flange adapter is required, install it before moving the bushing to the mounting hole. Put the gaskets and/or o-rings on the apparatus mounting surface per the apparatus instruction. Move the bushing to the mounting hole of apparatus. Tighten the bolts to the torque specified from the apparatus manufacturer.

8.4.3 Draw-Lead Connection

Bushings designed for draw-lead applications have the draw lead terminal, nut and pin in place. Before installation, you must remove the top terminal, the draw lead nut, the retaining pin and the draw lead terminal. Braze the apparatus cable to the draw lead terminal. Pass a wire or pull cord through the bushing center conductor from the top and attach it to the hole in the top end of the draw lead terminal on the flexible cable. While lowering the bushing into the opening in the cover, simultaneously pull the cable up through the center conductor. Secure the draw lead terminal into the top of the bushing by replacing the retaining pin through the conductor and then replace the draw lead nut. A light coating of silicone should be applied to the O-ring of the top terminal before replacing. Refer to the section Bolting and Terminal Torque Settings for terminal tightness.

8.4.4 Horizontal Mounting (88xxx Series: 25 kV ~ 69 kV Bushings)

The bushings are shipped with the oil reservoir-mounting hole plugged and with oil at the standard level for vertical mounting. The oil volume in all bushings fluctuates significantly with temperature. PCORE Series 88 bushings are designed to operate with air ambient from -50°C to +40°C. An oil reservoir tank mounted on the flange of an 88 series horizontally mounted bushing accommodates the oil volume change.

It is important to fill and install the bushing properly to guarantee long life expectancy. Two things are extremely important. First, all air must be out of the bushing, and secondly, the oil level must be adjusted properly according to

the bushing oil temperature. Failure to follow these instructions can cause bushing failure.

Before installing the bushing into the equipment (or wall), perform the following steps while the bushing is held horizontally

- A. Remove the oil filler plug in the stainless steel cover at the top of the bushing.
- B. Add oil through the fill hole in the top cover until the bushing is completely full. Tip the bushing slightly so the air bubble is at the fill hole in the top cover. Fill with oil until some oil comes out of the fill hole in the top cover. Use the extra oil supplied with the bushing, or any NON-PCB type I or type II transformer oil. The oil must meet the minimum requirements for new transformer oil per IEEE C57.106 (latest revision).
- C. Replace the fill plug in the top cover and tighten slightly by hand. Rock the bushing back and forth to release all entrapped air inside the bushing into the sight glass area. Watch the sight glass for air bubbles. Continue rocking until no the air is being released into the sight glass. More oil may have to be added to the bushing.
- D. Loosen the oil filler plug in the top bushing cover to bleed off the entrapped air (air bubble).
- E. Add oil to the bushing until oil comes out of the fill hole in the top cover. Be sure the fill hole in the top cover is slightly higher than the bottom of the bushing.
- F. Repeat steps B through E as necessary until the air bubble that remains inside the sight glass is less than 1/4 inch in diameter. **DO NOT STORE THE BUSHING COMPLETELY FILLED.** Any oil expansion could cause the bushing to leak.

Install the bushing in the apparatus and perform the following steps immediately. It is important to keep the bushing in a horizontal position during installation.

- G. Remove the oil reservoir plug from the flange and install the oil reservoir. Be sure the O-ring is properly installed on the reservoir.
- H. Remove the oil filler plug from the oil reservoir top. **IT IS IMPORTANT TO DETERMINE THE TEMPERATURE OF THE OIL IN THE BUSHING BEFORE ADJUSTING THE LEVEL. THIS MAY BE DIFFERENT THAN THE AMBIENT AIR.** The best method is to use a dial thermometer or a thermocouple inserted as far into the reservoir as possible. Try to get into the flange through the neck of the reservoir. **DO NOT USE A GLASS THERMOMETER.** Wait a few minutes for the reading to stabilize.
- I. Add oil to the reservoir until the oil level in the reservoir is at the proper level. **FOR PROPER OIL LEVEL INDICATION, THE OIL THAT YOU ADD TO THE RESERVOIR SHOULD BE THE SAME TEMPERATURE AS THE OIL IN THE BUSHING.** Use the dip stick to measure the oil level. The top mark is for 55°C, the second is 40°C, the middle for 25°C, the fourth for 10°C, and the bottom for -5°C oil temperature. Interpolation between marks is not critical. If in doubt, use slightly less oil. Interpolation between marks is not critical. If in doubt, use slightly less oil.
- J. Tighten the oil fill plug in the bushing cover and install the oil fill plug in the oil reservoir top. Make sure the O-rings are properly installed and seated on the plugs.

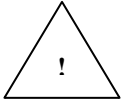

WARNING

Do not operate a bushing with the bushing oil level not visible in the sight glass under normal ambient conditions. This could result in serious damage to the bushing and/or apparatus on which the bushing is being mounted.

Under these conditions, operation may result in severe personal injury, death or property damage. It is normal for the oil level to drop below the sight glass in some bushings in extremely cold conditions. Contact PCORE Electric Company if you have any questions.

8.4.5 Torque Specifications for Bolts

Before mounting bushings to the apparatus cover, inspect and clean the mounting surfaces of both the bushing and apparatus. Install the gasket or O-ring supplied by the apparatus manufacturer. Secure the bushing on the apparatus cover by tightening all the bolts uniformly in several steps. Do not attempt to pull the bolts down to the final setting on the first tightening. It is good practice to allow time between the several tightening steps for the gasket to set. Care in tightening avoids possible damage or distortion of the mounting flange. Normally, the torque values as listed will provide adequate compression for sealing.

Use the torque recommendations and mounting specification of the apparatus manufacturer. Reduce torque if gasketed per manufacturing recommendations for material being used. Adjust torque for other metals for bolts in flange. Values below are for SAE Grade 1 or 2.

BUSHING FLANGE

Bolt Diameter (inch)	Torque (ft-lb)
3/4	105
1	200
1 1/8	250

DRAW LEADS

Current (ampere)	Bolt Diameter (inch)	Torque (ft-lb)
400	3/4	20
800	1 1/4	40

TOP TERMINALS

Current (ampere)	Bolt Diameter (inch)	Torque (ft-lb)
400/1200	1 1/8	80
800/1200	1 1/2	80
1600/2000	2	80

8.4.6 Bottom Terminal and Shields

If a bottom terminal and shield are to be installed, pass the cable through the hole in the shield and mount the bottom terminal. Mount the terminal. Then push the shield to the bushing and mount the shield on the bushing.

8.4.7 Top Terminals

After necessary tests are done for the apparatus, install the top terminal for energization.

9. Partial Discharge Tests

PCORE does NOT add a pressurized gas blanket over the top of the oil in the bushings. It is possible to encounter some partial discharges in the sight glass during overvoltage tests. The partial discharges are a result of a partial vacuum formed in the gas space above the oil. The condition occurs most often after transformer heat-run tests. It can be eliminated by venting the gas space to atmospheric pressure.



CAUTION

When the bushing is hot, do NOT remove oil fill plug.

10. Energization

During initial energization, you should monitor oil level changes. If oil level changes excessively, contact the factory in LeRoy.

11. Maintenance

Little maintenance is required other than periodically checking the oil level as indicated in the sight glass or the magnetic oil level gage. Unless a bushing is damaged, the oil level should remain within the sight glass or indicate normal with the oil level gage, fluctuating slightly with thermal and ambient conditions.

Although we discourage the breaking of the seal of the oil-fill plug in the bushing reservoir; if the oil level over an observed period of time remains low and ambient conditions are normal, oil may be added. However, contact the factory in LeRoy first.

Removal of oil filler plug should be done only in a dry atmosphere. Provide oil that meets the IEEE C57. 106 standard for new transformer oil. If there is mechanical damage to the bushing which results in loss of oil, or the oil level in the bushing is still indicating low after the addition of oil the bushing should be taken out of service.



WARNING

Never operate or test a bushing with a low internal oil level. Under these conditions, operation may result in severe personal injury, death or property damage

Bushings exposed to salt spray, cements dust, and other abnormal contamination deposits are subject to a special hazard and must be cleaned regularly to prevent flashover and corrosion of metal parts. The sight glass should also be cleaned regularly. We endorse and recommend the

measurement of power factor and capacitance at the time of installation and repeating the measurement regularly., These values should be used as a base to compare the TRENDS of future measurements. Field measurements of power factor and capacitance may differ from measurements made under the controlled conditions in the factory. Contact the factory if you encounter any of the following:

- A. Measurement of power factor increases to 1.5 times the original installation value.
- B. Measurement of capacitance increases by 10 percent over the original installation value.

12. Re-shipping or Returning Bushings

To ship the bushing to another site, you may re-use the original crate. **Inspect the crate for damage and repair before using.**

Bushings with damaged porcelain or sight glasses pose a significant danger. The entire assembly is under compressive load, releasing that load suddenly may cause the bushing to explode. Wrap broken porcelain or glasses with duct tape and blankets (Burlap works well).

It is recommended that bushings be returned to the factory for all significant repairs . Inquiries concerning repairs should be addressed to the factory at Le Roy. You MUST obtain a Return Authorization(RO) number before shipping bushings or bushing attachments to PCORE. The handling of all requests will be expedited if the factory is furnished the catalog number and the serial number which are on the nameplate. The catalog number identifies the bushing rating. The first two digits of the serial number are the last two digits of the manufacturing year.

Do not attempt field repairs.

A bushing experiencing a core problem may have a high pressure and/or hot oil inside. Do not remove oil fill plug.

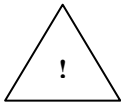

WARNING

Bushings are assembled using heavy clamping pressures. A bushing with a shattered oil sight glass must be wrapped with burlap and duct tape before the bushing is removed from installation.